

STD-302 429MHz test data for half duplex communication

By Masayasu Komiyama

1. Half-duplex data communication test (Data rate 4800bps)

TEST procedure:

Transmission DATA (1 byte) is fed following 10 ms preamble (11001100..repeated 48bits) and 5ms Sync signal in master unit.

Slave unit returns received data to Master unit after performing data frame confirmation (Loop back function).

Temperature Condition: Master: at -30°C^{*1} Slave: In the room temperature ($+28 \pm 5^{\circ}\text{C}$)

Frequency drift at the temperature: Master: -3.3 kHz Slave: 0 kHz

(Total 3.3 kHz difference is considered as the worst condition when unit work within -10°C to $+60^{\circ}\text{C}$)

Test result: OK: 0(zero) error occur during 10,000 packets transmission.

*1: -30°C temperature was set to create 3.3 kHz frequency drift. This does not ensure the operation of STD-302 at this temperature.

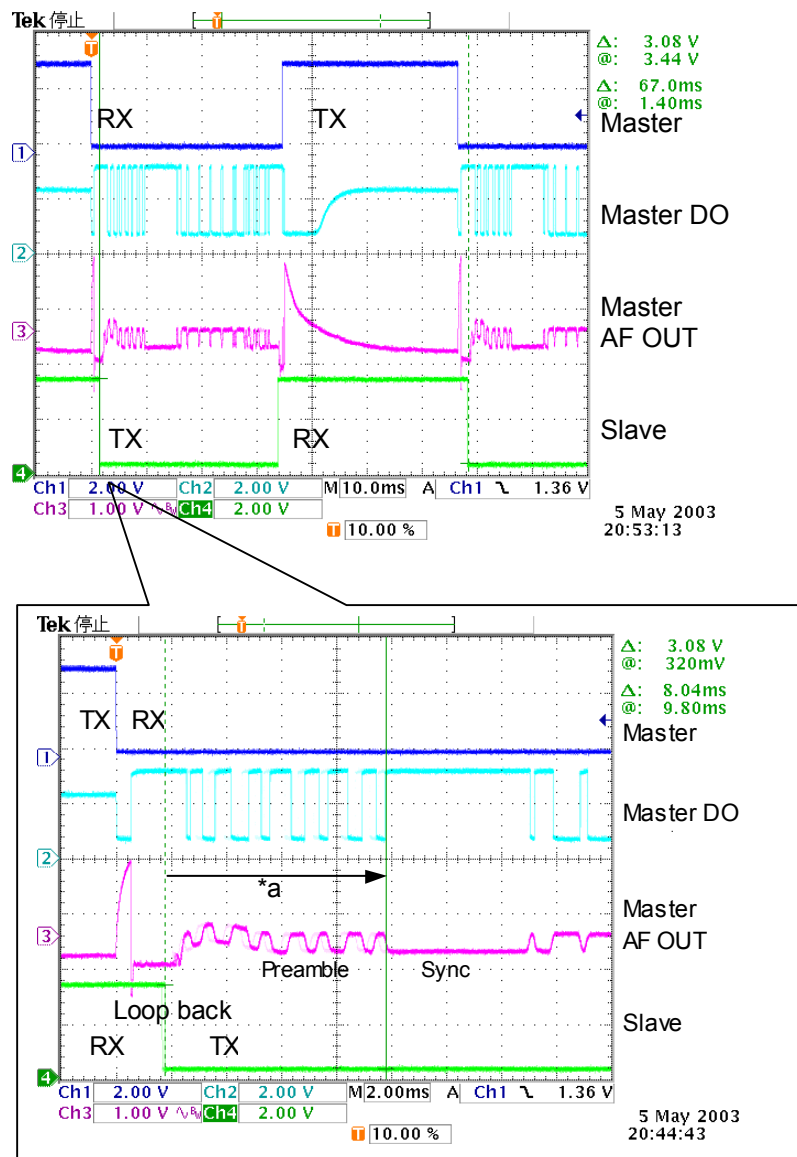

Temperature Condition: Master: at +78°C*1 Slave: In the room temperature (+28 +/-5°C)
 Frequency drift at the temperature: Master: +3.3kHz Slave: 0kHz
 (Total 3.3kHz difference is considered as worst condition when unit work within -10°C to 60°C)

Test result: OK: 0(zero) error occur during 10,000 packets transmission.

*1: +78 °C temperature was set to create 3.3kHz frequency drift. This does not ensure the operation of STD-302 at this temperature.

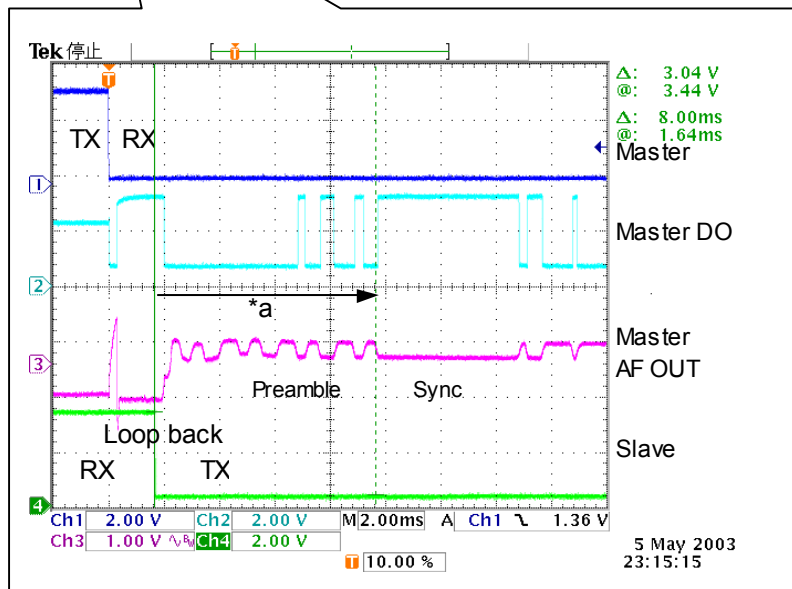
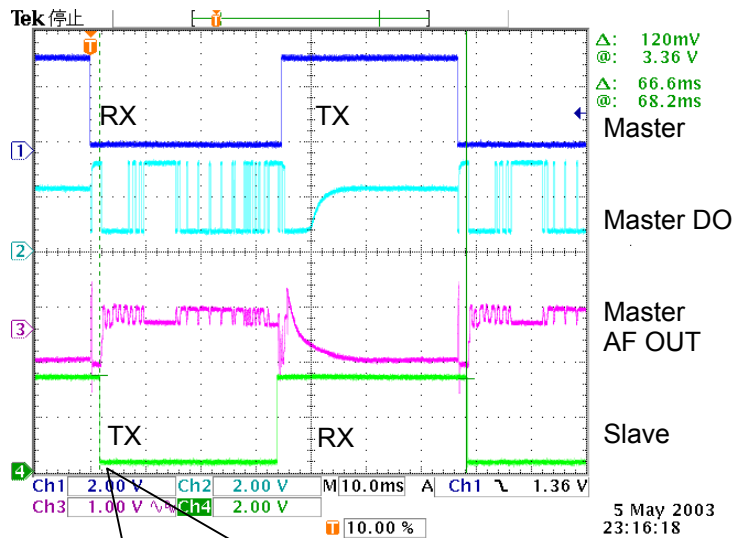

Time required for the data becomes valid at TX -> RX, RX-> TX operation varies by ambient temperature. **Recommended preamble periods (≈ Time required for the data from DO becomes valid. Marked with *a in figures) are shown in below.**

Same preamble periods are recommended even the transceiver in the system is set continuous receiving.

-10°C to +55°C: 15 ms or more

-20°C to +65°C (excluding the above range): 20 ms or more

Timing may change by setting method of PLL and/or antenna location. User is recommended to check and verify the operation behavior and optimize the timing.

2. Receiver frequency change timing (12.5kHz & 100kHz change)

Test signal: 4800bps 110011001100....repeated signal

- A. Temperature condition: -30°C
- Frequency drift -3.3kHz

RX frequency change:

429.5000 MHz -> 429.4875 MHz (-12.5 kHz)

429.4750 MHz -> 429.4875MHz (+12.5kHz)

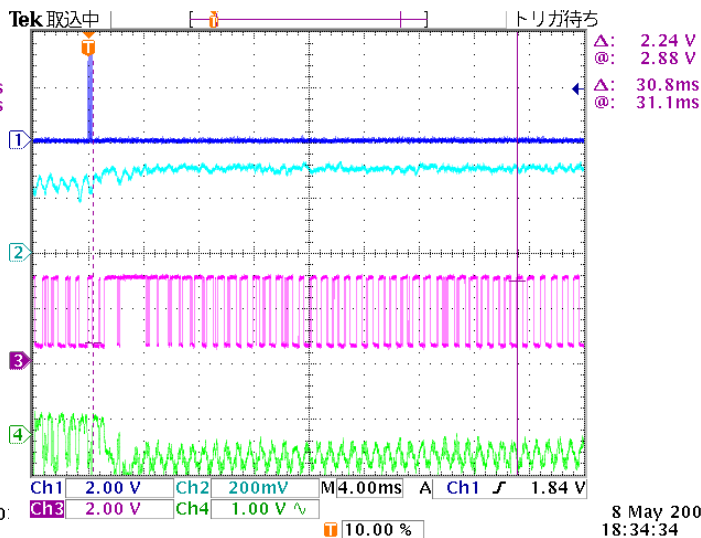
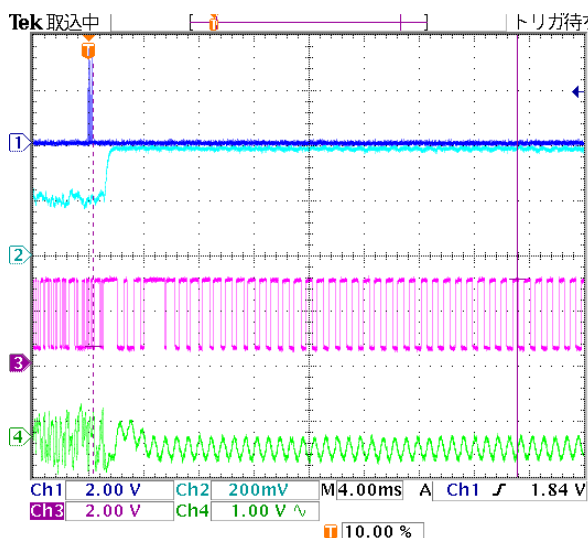

RX frequency change:

429.5875 MHz -> 429.4875 MHz (-100 kHz)

429.3875 MHz -> 429.4875 MHz (+100 kHz)

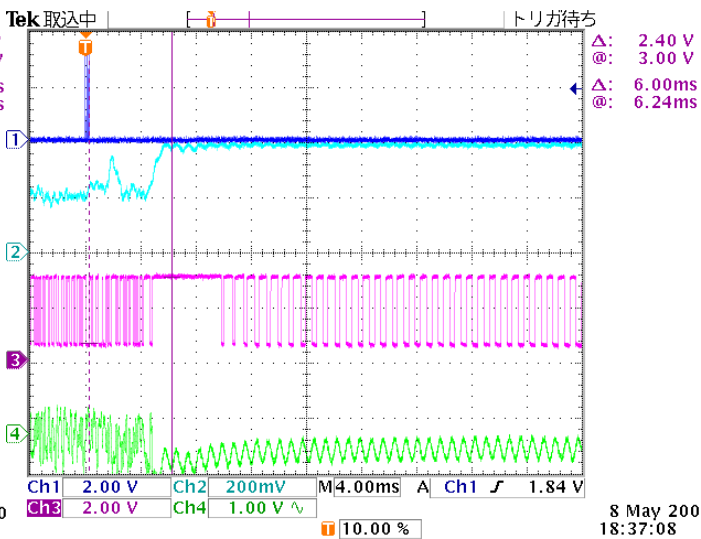
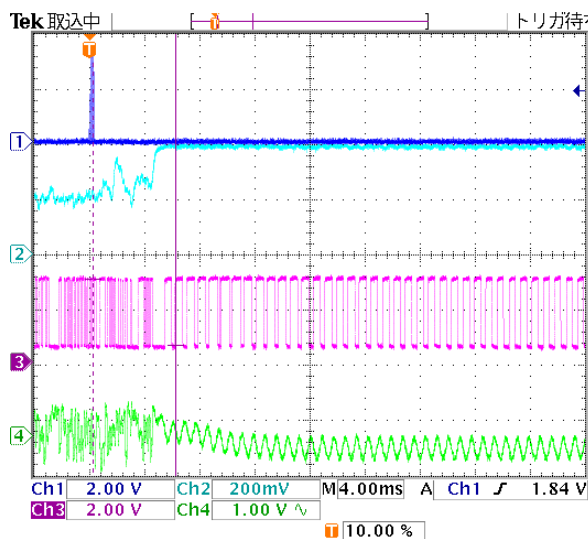

B. Temperature condition: +78°C
 Frequency drift +3.3kHz

RX frequency change:

429.5000 MHz -> 429.4875 MHz (-12.5 kHz)

429.4750 MHz -> 429.4875 MHz (+12.5 kHz)

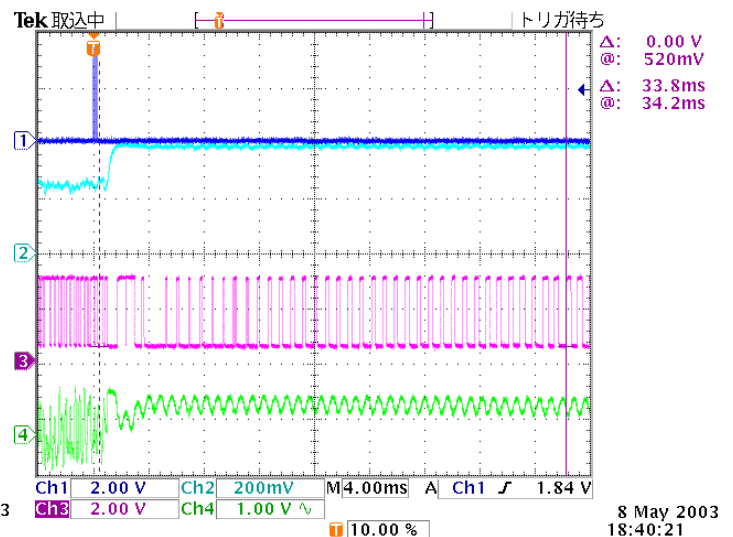
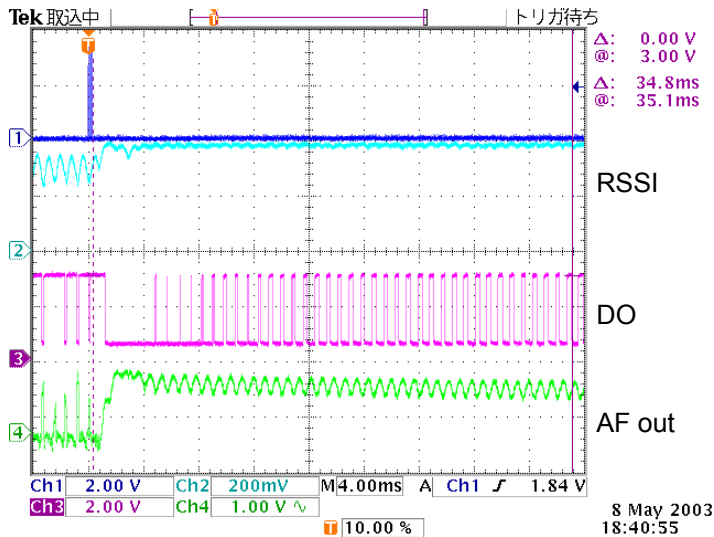

RX frequency change:

429.5875 MHz -> 429.4875 MHz (-100kHz)

429.3875 MHz -> 429.4875 MHz (+100kHz)

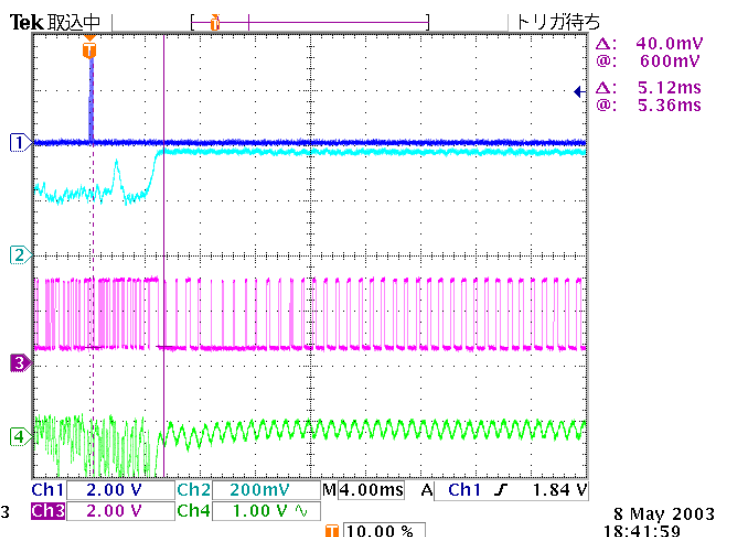
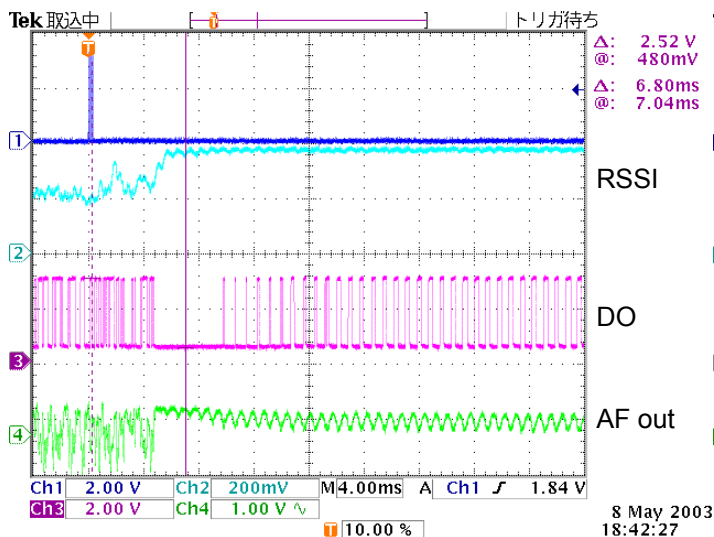

Recommended timing for RX frequency shift

- * RSSI rise (12.5kHz or 100kHz shift)
 - 20°C to +65°C 12ms
- * Valid output data (12.5kHz shift)
 - 10°C to +55°C: 40ms or more
 - 20°C to +65°C (excluding the above range): 50ms or more

Timing may change by setting method of PLL and/or antenna location. User is recommended to check and verify the operation behavior and optimize the timing.

3. Temperature vs Frequency drift

PLL reference X'tal Temperature characteristics

- +/- 4ppm -10°C to +55°C
- +/- 9ppm -20°C to +65°C (excluding the above range)

Blue line: Temperature characteristics worst case presented by X'tal manufacturer

Red line: Frequency drift temperature characteristics compensated by STD-302 internal circuit.

At -20 degree C, -4.12kHz frequency drift that X'tal itself show is improved to -2.15kHz.

Fig. Crystal frequency drift data

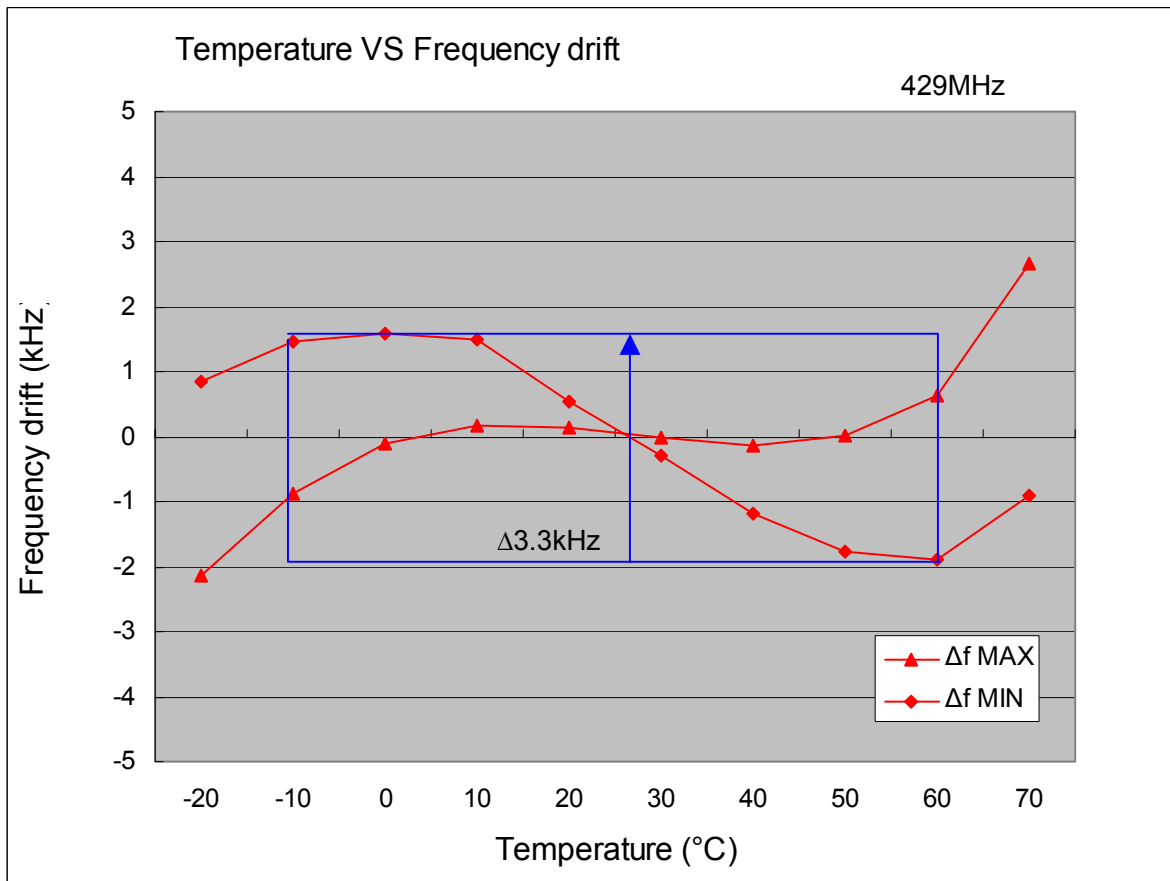

Circuit Design, Inc. All rights reserved.

No part of this document may be copied or distributed in part or in whole without the prior written consent of Circuit Design, Inc.